

# **JOC Nuts & Bolts – RS Means**

JOC

*AASBO Summer Conference  
July 20, 2012*

**Rick Carr, Arcadis U.S., Inc.  
Tim O'Malley, The O'Malley Group  
Bill Brannen, Mohave Educational Services Cooperative**

## **This presentation will cover:**

- What is JOC?
- JOC contracting terms
- JOC experience
- Types of JOC projects
- Benefits of JOC
- Steps in a typical JOC project and how projects are priced
- Keys to success

## Job Order Contracting ...

- is a project delivery method (still statutorily termed Alternative Project Delivery Method or APDM) using an Indefinite Delivery, Indefinite Quantity (IDIQ) contract for a specified period of time.
- provides an "on-call" contractor at a guaranteed competitive rate structure.
- is targeted for small to medium sized construction projects.
- has a specified term, generally up to five years.
- prices can be based on a coefficient tied to a Unit Price Book (UPB) such as RS Means, or other pricing methods.

What is JOC?

## **Job Order Contracting is a project delivery method in which...**

- The contract to be performed is specified in delivery orders issued during the contract.
- Finance services, maintenance services, operations services, preconstruction services, design services, and other related services may be included.
- The JOC contractor bids a coefficient or coefficients that include direct and indirect costs and overhead & profit.

## **JOC is used in...**

- K-12
- Municipalities/Counties
- Higher Education
- Government Housing
- Federal Government
- Military
- Private Sector
- Transportation (i.e. ADOT)

Where is JOC used?

- JOC - Acronym for Job Order Contracting
- IDIQ - Indefinite Delivery/Indefinite Quantity
- UPB - Unit Price Book
- Open Book Pricing – Alternative pricing based on sub contractor bids.
- RS Means - Industry standard unit price cost book
- Coefficient - Multiplier applied to UPB
- Task Order, Delivery Order or Job Order - Individual construction projects performed under the umbrella procurement
- Non-prepriced item - A construction task added to the UPB

## **JOC Contracts:**

- Solicited through the one or two-part procurement process outlined in A.R.S. §41-2578
- Qualifications-based selection resulted in contracts with experienced JOC contractors
- Provide for a broad range of construction services
- Contain provisions for adding non-prepriced items to cover unforeseen requirements
- Contractors have proven ability to perform construction services throughout Arizona
- Provide quality construction services at fair value

## **JOC Contracts:**

- Contractors are licensed, bonded & insured
- Performance and payment bonds are provided for job orders
- Liquidated damages are available
- Progress payments are available
- Payment Retention is available
- Require member involvement



**JOC is intended for minor new construction, renovations, repairs and additions, including but not limited to the following...**

- Any project that is operating under pressure due to time constraints
- Minor construction projects (generally under \$1 Million)
- HVAC and Electrical
- Routine repairs
- Renovations of all types
- Upgrades to ADA standards
- Emergency repairs
- Site work and utilities
- Parks and playgrounds
- Upgrade landscaping
- Classroom additions
- Complete new buildings
- Replace flooring

## Top Five Reasons JOC is a Method of Choice for Many

- Reason #1: Immediate access to negotiated contract, defines expected level of service
- Reason #2: Reduces Lead Time/Defined Schedule
- Reason #3: Quality/Efficiencies Increase
- Reason #4: Extension of staff
- Reason #5: Cost/Budget advantages

JOC is not always the cheapest method, but often it is the most cost effective and efficient method.

## **Reason #1: Immediate Access**

- Pre-negotiated JOC contracts with qualified vendors, can be used immediately
- You may retain the same awarded contractor(s) for the same amount time as a traditional Bid or RFP (up to five years from time of award under Arizona Statute)
- BUT, must ensure scope and type of work was what was contracted for just like other procurement actions

## Reason #2: Schedule

- Allows for faster response to customer needs
- Reduces disruptions to on-going operations through flexible scheduling
- Eliminates the need for multiple project solicitations
- Provides quick response to changing market conditions



## Schedule

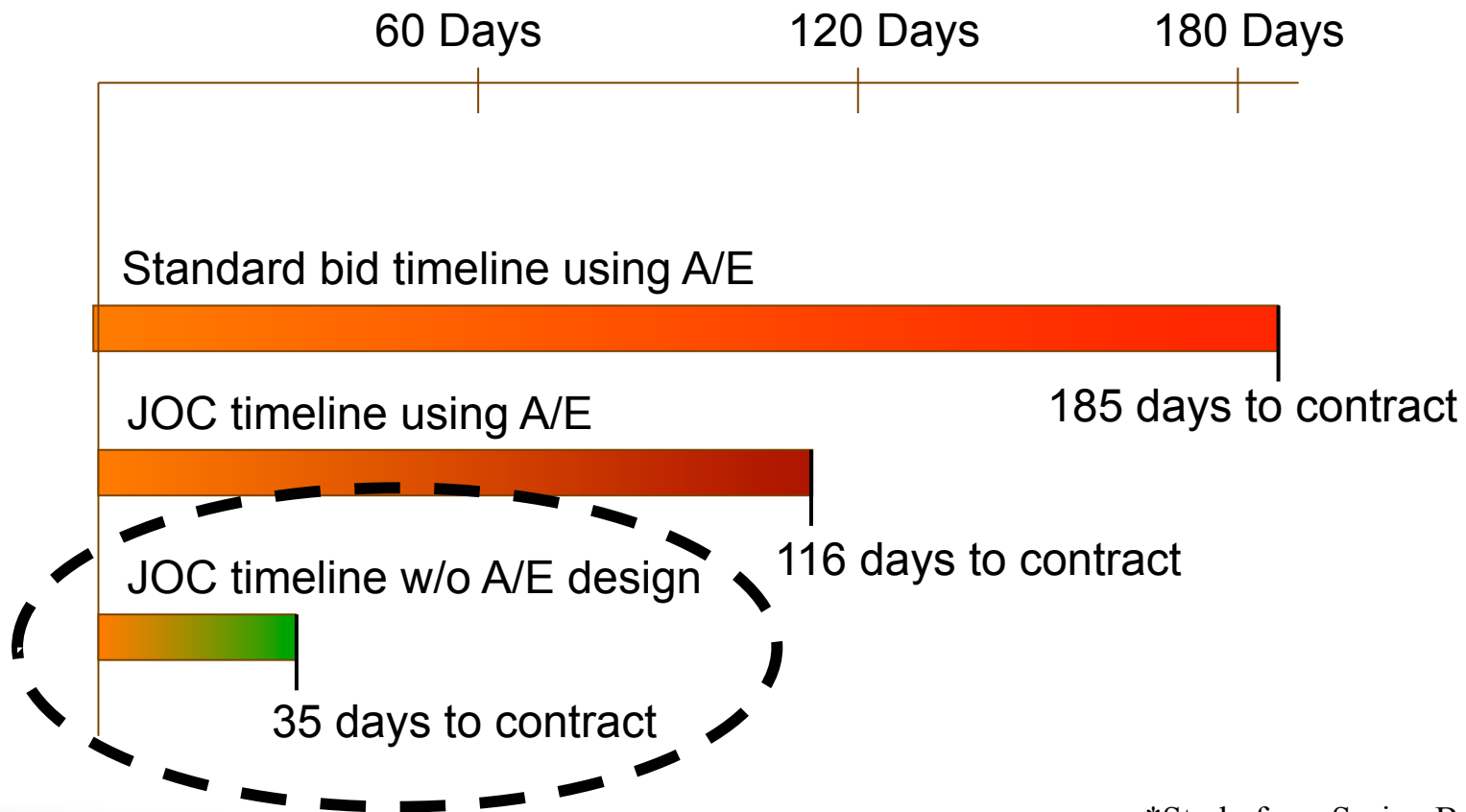

\*Study from Spring Branch, TX

Benefits of JOC

### **Reason #3: Quality**

- Proven general contractors ensure top quality performance
- Team environment encourages quality collaboration
- High quality work ensures repeat business and develops relationships



## Reason #4: Extension of staff

- Predictability of project results
- Costs, schedule, safety, and quality
- Dependability
- Collaborative approach
- Reduced risk
- Increases MBE/WBE and small business participation



## Reason #5: Cost Effective/Best Value

- Dramatically decreases up-front design, procurement and administrative costs
- Maximizes the dollars for in-place construction
- Provides an extension of the owner's staff
- Reduces backlog of maintenance, repair and renovations
- Provides a complete proposal before the P.O. is written
- Allows scope and budget alterations with defined costs
- Reduces or eliminates claims, litigation and change orders

Note: RS Means pricing may not be 100% accurate when comparing local pricing. For instance, a recent comparison on sheet rock showed Lowe's @ \$9.98, RS Means was \$10.56.





## The Typical JOC Process:

- Scoping Session
- Scoping Confirmation
- Estimate Preparation
- Plan the Job/Submit PO
- Construction Performed
- Updates
- Final Inspection
- Close Out
- Warranty Issues

Begin



End



Steps in a JOC process

## Initial Request (Getting the Owner's Thoughts on Paper)

- Are all the interested parties represented?
- Who are the decision makers?
- Is the project funded?
- Is the project under \$1 Million?
- Do you have any pre-determined expectations?
- Are there special wage considerations (i.e., federal funded projects)?
- Are you relying on existing plans, estimates or budgets?
- Are there any time or critical constraints?
- Are permits required?
- Are there MBE/WBE goals?



## Scoping Session

- Visit the jobsite and document conditions
- Establish project goals
- Determine if design services are required
- Define building systems and quality of materials
- Identify client's responsibilities
- Determine project schedule and major milestones
- Identify safety, security and hazardous material issues



## Scope Confirmation

- Confirm scope of work and quantities
- Review any qualifications and assumptions
- Revise the scope as necessary
- Perform value engineering
- Review the schedule
- Confirm start and completion dates
- Understand and mitigate impacts on existing operations and facilities
- Review safety concerns and requirements



# Estimate Preparation

- Determine whether to use UPB pricing, or an alternate method, such as Open Book Pricing, if available.
- Vendor and member determine quantities of work.
- Vendor creates an estimate, based on scope
- For UPB pricing, the line item estimate is totaled and a coefficient is applied.
- A city cost index is applied, if applicable.
- Applicable bond, permit & taxes.

C INTERIORS

**C10 Interior Construction**

**C1010 Partitions**

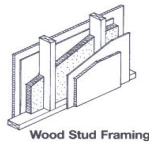

Wood Stud Framing

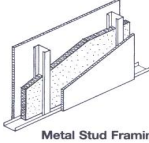

Metal Stud Framing

The Drywall Partitions/Stud Framing Systems are defined by type of drywall and number of layers, type and spacing of stud framing, and treatment on the opposite face. Components include taping and finishing.

Cost differences between regular and fire resistant drywall are negligible, and terminology is interchangeable. In some cases fiberglass insulation is included for additional sound deadening.

System Components	QUANTITY	UNIT	COST PER S.F.		
			MAT.	INST.	TOTAL
SYSTEM C1010 124 1250 DRYWALL PARTITION, 5/8" F.R.1 SIDE, 5/8" REG.1 SIDE, 2"x4" STUDS, 16" O.C. Gypsum plasterboard, nailed/screwed to studs, 5/8" F.R. fire resistant Gypsum plasterboard, nailed/screwed to studs, 5/8" regular Taping and finishing joints Framing, 2 x 4 studs @ 16" O.C., 10' high	1.000	S.F.	.25	.39	.64
	1.000	S.F.	.24	.39	.63
	2.000	S.F.	.08	.78	.86
	1.000	S.F.	.38	.79	1.17
<b>TOTAL</b>			<b>.95</b>	<b>2.35</b>	<b>3.30</b>

C1010 124	Drywall Partitions/Wood Stud Framing					COST PER S.F.		
	FACE LAYER	BASE LAYER	FRAMING	OPPOSITE FACE	INSULATION	MAT.	INST.	TOTAL
1200	5/8" FR drywall	none	2 x 4, @ 16" O.C.	same	0	.96	2.35	3.31
1250				5/8" reg. drywall	0	.95	2.35	3.30
1300				nothing	0	.67	1.57	2.24
1400		1/4" SD gypsum	2 x 4 @ 16" O.C.	same	1-1/2" fiberglass	1.89	3.62	5.51
1450				5/8" FR drywall	1-1/2" fiberglass	1.65	3.18	4.83
1500				nothing	1-1/2" fiberglass	1.36	2.40	3.76
1600		resil. channels	2 x 4 @ 16", O.C.	same	1-1/2" fiberglass	1.66	4.60	6.26
1650				5/8" FR drywall	1-1/2" fiberglass	1.53	3.67	5.20
1700				nothing	1-1/2" fiberglass	1.24	2.89	4.13
1800		5/8" FR drywall	2 x 4 @ 24" O.C.	same	0	1.37	2.97	4.34
1850				5/8" FR drywall	0	1.12	2.58	3.70
1900				nothing	0	.83	1.80	2.63
1950		5/8" FR drywall	2 x 4, 16" O.C.	same	0	1.46	3.13	4.59
1955				5/8" FR drywall	0	1.21	2.74	3.95
2000				nothing	0	.92	1.96	2.88
2010		5/8" FR drywall	staggered, 6" plate	same	0	1.85	3.94	5.79
2015				5/8" FR drywall	0	1.60	3.55	5.15
2020				nothing	0	1.31	2.77	4.08
2200		5/8" FR drywall	2 rows-2 x 4 16" O.C.	same	2" fiberglass	2.34	4.31	6.65
2250				5/8" FR drywall	2" fiberglass	2.09	3.92	6.01
2300				nothing	2" fiberglass	1.80	3.14	4.94
2400	5/8" WR drywall	none	2 x 4, @ 16" O.C.	same	0	1.10	2.35	3.45
2450				5/8" FR drywall	0	1.03	2.35	3.38
2500				nothing	0	.74	1.57	2.31
2600		5/8" FR drywall	2 x 4, @ 24" O.C.	same	0	1.51	2.97	4.48
2650				5/8" FR drywall	0	1.19	2.58	3.77
2700				nothing	0	.90	1.80	2.70

230 Important: See the Reference Section for critical supporting data - Reference Numbers and City Cost Indexes

Steps in a JOC process



# Example of UPB based estimate

## JOC Estimate Example Interior Wall Partition Detail

3/5/2003

Group	Phase	RS Means Index No.	Description	Takeoff Quantity	Total Unit w/OH&P & CCI	Total Adjusted Amount	City Cost Index %
<b>07200.000</b>			<b>THERMAL PROTECTION</b>				
	07210.960		Wall cing insl, non-rigid				
		0820	Wall/ceiling insul, fibgls, unfaced, batt/bltd, 3.5" thk, R11, 15' W	1,000.00 sf	0.46 /sf	459.00	93.1%
<b>09100.000</b>			<b>METAL SUPPORT ASSEMBLIES</b>				
	09110.100		Metal studs, partitions				
		2300	Metal studs ptn, 10' H, N.L.B., galv, 25 ga 3-5/8" W, 16" OC	1,000.00 sf	0.88 /sf	882.00	3%
<b>09200.000</b>			<b>PLASTER &amp; GYPSUM BOARD</b>				
	09260.700		Drywall				
		2050	Drywall,gyp plasbd,nailed/sord to std,5/8" thk	1,000.00 sf	0.91 /sf	910.00	
		2150	Drywall,gyp plasbd,nailed/sord to std,5/8" thk, res,taped&fn	1,000.00 sf	0.92 /sf	920.00	
<b>00.000</b>			<b>FLOORING</b>				
	09658.100		Resilient flooring				
		1150	Resilient, base, covr, rbr or vinyl, .080" thick, std colors, 4" hi	200.00 sf	1.42 /sf	284.60	96.0%
<b>09900.000</b>			<b>PAINTS &amp; COATINGS</b>				
	09910.920		Walls and ceilings				
		0340	Walls&clgs,conc/dry w/ptlas, oil base,prmr/sealer CT,sand fn,roller	2,000.00 sf	0.26 /sf	520.00	85.9%
		0840	Walls&clgs,conc,dry w/ or plas, oil base,prt 2 coats,sm fn,roller	2,000.00 sf	0.40 /sf	806.00	85.9%

CSI #

Quantity

Unit Cost w/OH & P

Apply City Cost Index

RS Means Index #

Apply Coefficient

Tax

Bonds

Total Cost

### Estimate Totals

Labor	3,242			68.53%
Material	1,542			32.59%
	<u>4,784</u>	4,784		101.13%
UPB Factor @ .93	(335)		(7.000) %	-7.08%
	<u>(335)</u>	4,449		94.05%
Sales/Gross Receipts Tax	234		5.270 %	4.95%
	<u>234</u>	4,683		99.00%
Performance & Payment Bond	47		1.000 %	0.99%
	<u>47</u>	4,730		99.99%
<b>Total</b>		<b>4,730</b>	4,730 /sf	

## UPB with Coefficient

Example:

Quantity x RS Means unit price	\$100.00	
Multiply by City Cost Index (.89)*		\$89.00
Multiply by Coefficient (1.05)	\$93.45	
Cost to member	\$93.45	

Note: City cost index varies by location of the work.  
Not all contracts use a city cost index.

## Open Book Pricing

- For general JOC contracts only, an alternate pricing method called open book pricing is available.
- Instead of using the UBP and coefficient, contractor obtains firm price quotes from qualified subcontractors and determines the firm general conditions cost for the project.
- General and administrative and profit multipliers are applied to direct project and general conditions cost to provide the net construction services cost.
- The pricing method to be used must be determined by the member and the contractor prior to quote preparation.



## Construction

- Contractor reviews the work plan again
- Contractor properly segregates the construction zone
- Contractor performs the work in a continuous and timely fashion

# Example JOC schedule

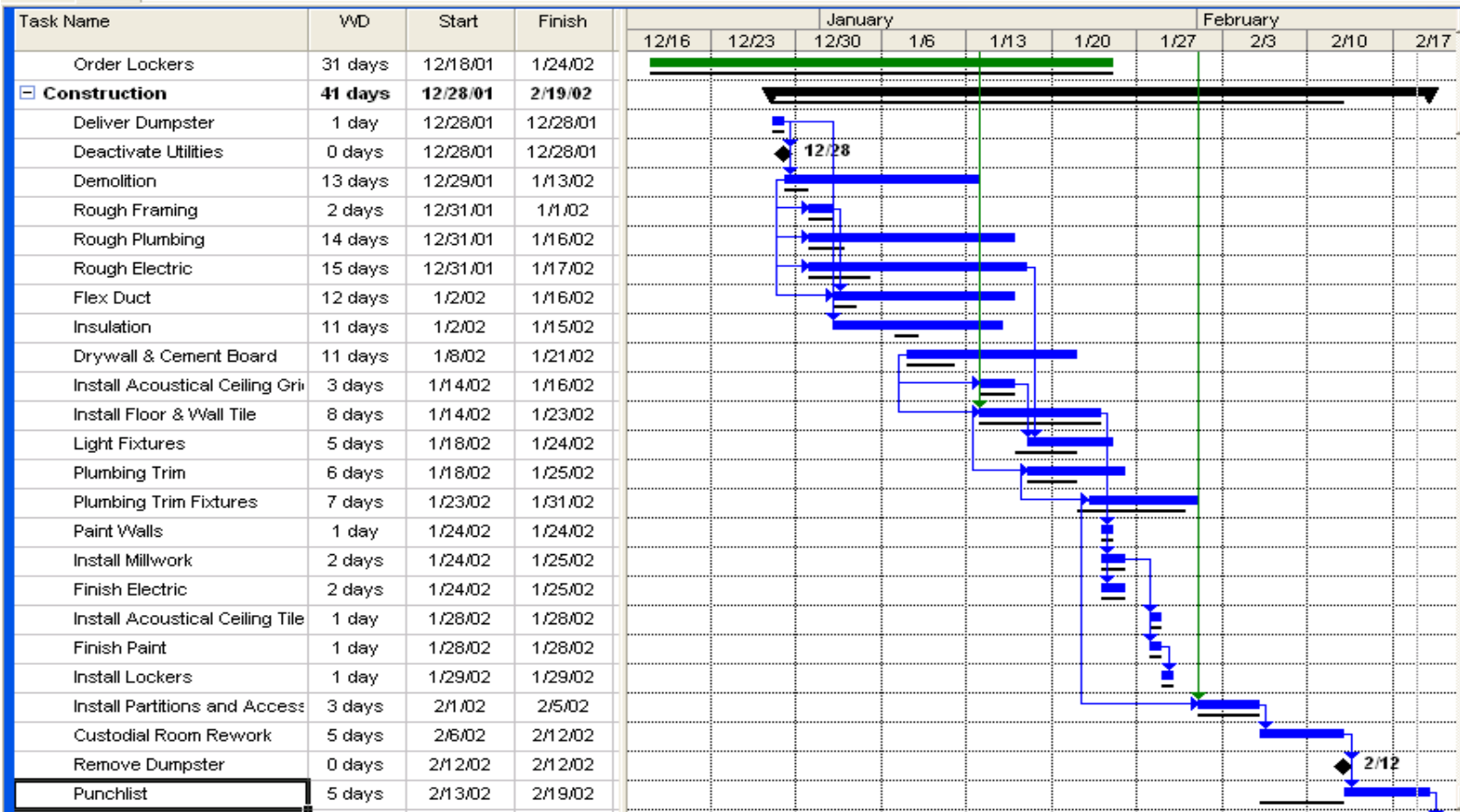

*Plan the Work... Work the Plan...*

Steps in a JOC process

# Updates

Contractor holds regular progress meetings on:

- Safety
- Schedule
- Construction issues
- Submittals
- RFI's

Central Arizona Project		Construction Meeting Minutes	
Bathroom Remodel			
Location: CAP HR Conference Room		Meeting Date: 16-Jan-02	
<input checked="" type="checkbox"/> Owner/User	<input type="checkbox"/> Project Manager	<input type="checkbox"/> Contractor	<input type="checkbox"/> Consultant
City of Phoenix (COP)	JD	Peterson Development	Constructors
<input type="checkbox"/> Paul Newman	<input type="checkbox"/> Ron Crawford	<input type="checkbox"/> Rob Peterson	<input type="checkbox"/>
<input type="checkbox"/> Bob King	<input type="checkbox"/> N.K. Hruszabidis	<input type="checkbox"/>	<input type="checkbox"/>
<input type="checkbox"/> Bill Gisher	<input type="checkbox"/>	<input type="checkbox"/>	<input type="checkbox"/>
<input type="checkbox"/>			<input type="checkbox"/>
<input type="checkbox"/>			<input type="checkbox"/>
<input type="checkbox"/>			<input type="checkbox"/>
<input type="checkbox"/>			<input type="checkbox"/>
<input type="checkbox"/>			<input type="checkbox"/>
<input type="checkbox"/>			<input type="checkbox"/>
<input checked="" type="checkbox"/> = attendee	<input checked="" type="checkbox"/> = copy only		

Item	Description	Responsible Party/ Due Date
1.0	Corrections/Additions/Comments to Previous Meeting Minutes - 10/19/01	
2.0	Schedule & Coordination with Separate Contractors	
2321	<b>Progress</b> <ul style="list-style-type: none"> <li>• All demolition is complete.</li> <li>• Floor tile in the Men's bathroom is complete.</li> <li>• Wall tile in the Men's bathroom in progress.</li> <li>• Rough plumbing complete in the Women's bathroom.</li> </ul>	3D/1
2322	<b>Master schedule</b> <ul style="list-style-type: none"> <li>• Review updated schedule.</li> </ul>	3D/1

Steps in a JOC process

## Final Inspections

Contractor will:

- Walk the project at completion
- Provide closeout documentation
- Train the facility managers
- Manage the warranty process



Steps in a JOC process

## Close Out

- Feedback
- Have a post completion meeting with the users
- Deliver close out documents, as-builts, warranties, etc.
- Customer surveys
- Follow up visits



Steps in a JOC process





Benefits of JOC

## Remember:

- Ensure the project is funded or that funding is readily available
- Owner's representative must understand JOC
- Not simply another price quote for the work
- Not a free estimating service
- Owner still has a lot involvement in the job
- Allow adequate time for the process
- Contractor invests a lot of front end effort
- Owner can expect excellent execution of the work
- JOC eliminates most change orders
- Ensure that all owner & contractor stakeholders have had sufficient input into the job
- Ensure owner & contractor consensus on scope, schedule and cost
- Owner & contractor must each holdup its end of the bargain
- Successful JOC is a non-adversarial relationship

***ANY  
QUESTIONS?***

Questions



# Thank You!

Rick Carr

Tim O'Malley

Bill Brannen

AASBO Summer Conference---July 20, 2012